

# Base frame

40/40/2  
square profile

40/20/2  
rectangular profile

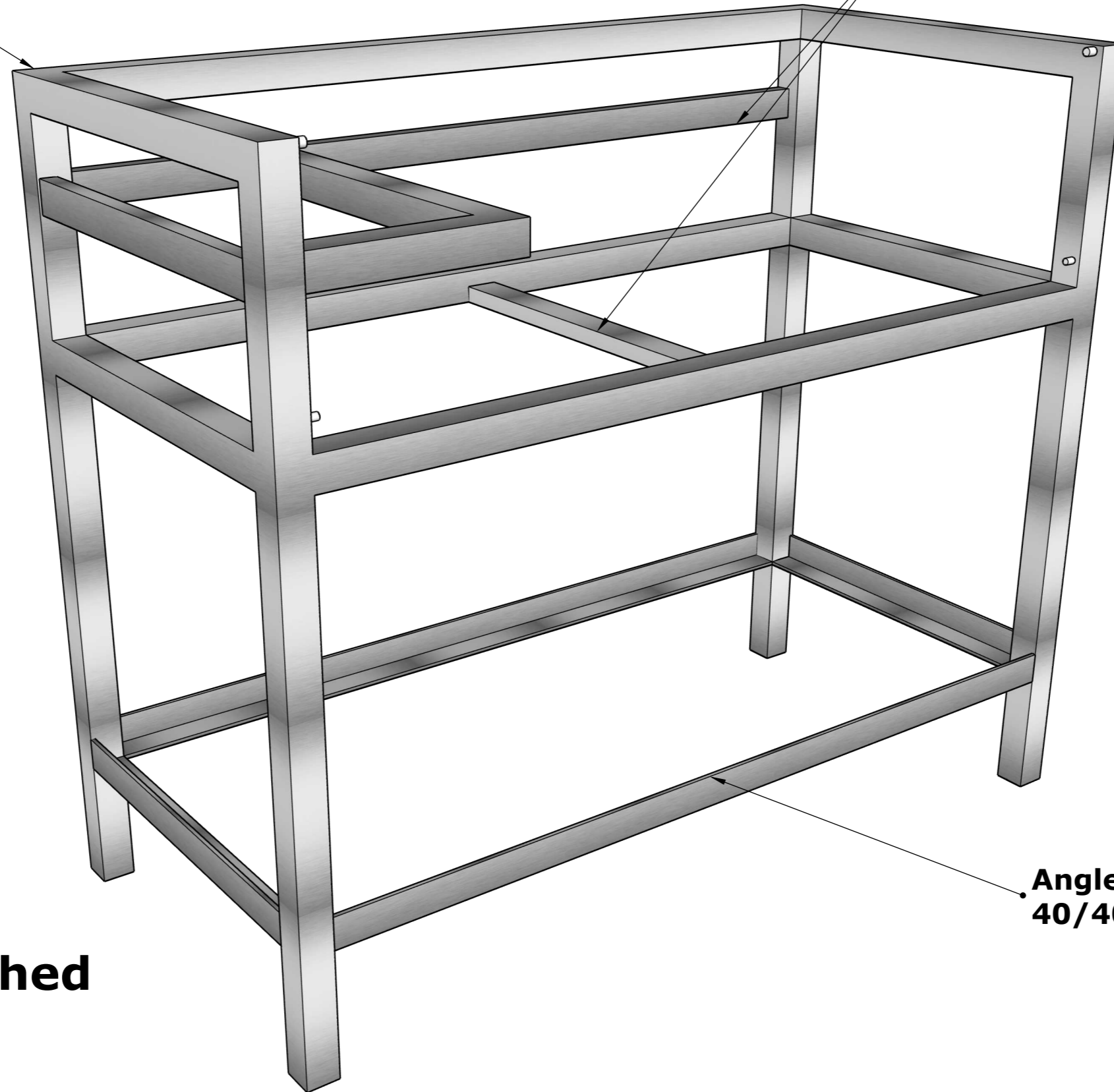

All profiles:  
1.4301 brushed  
K320

Angle profile  
40/40/3

# Base frame

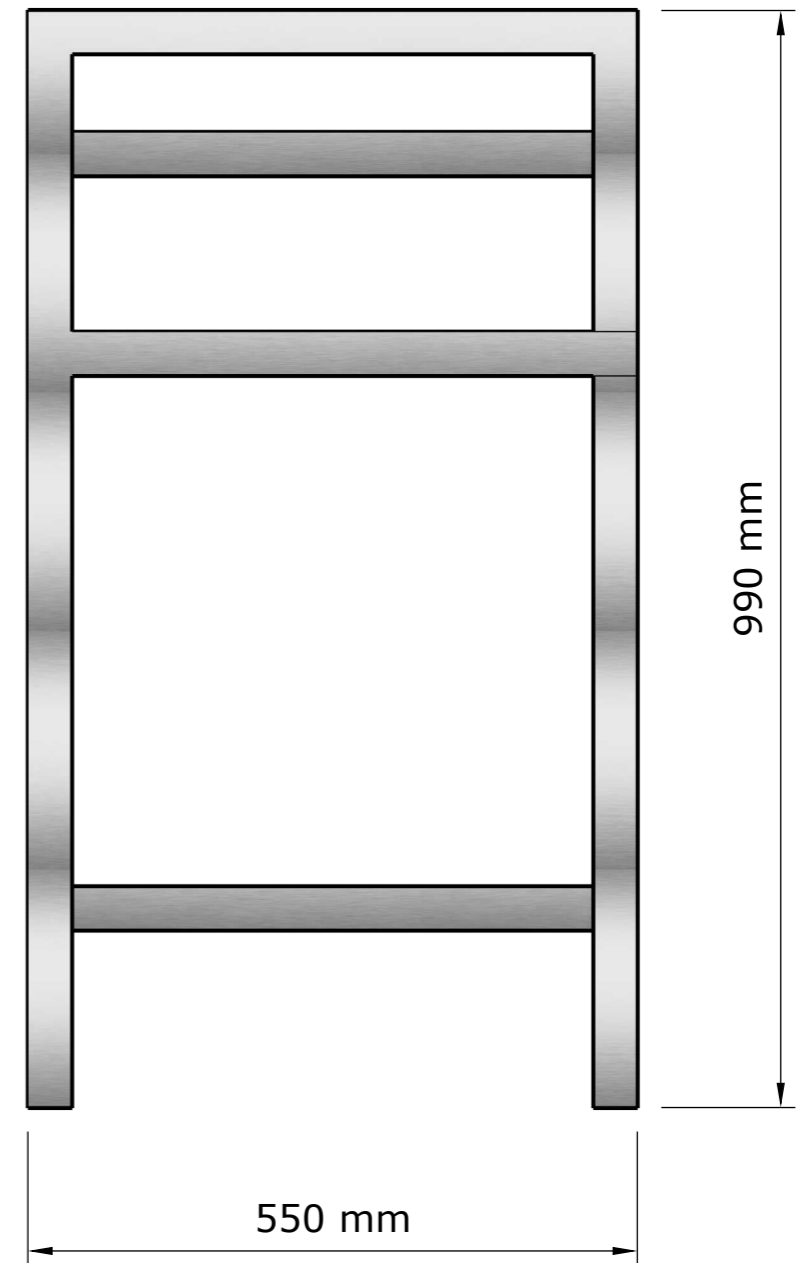
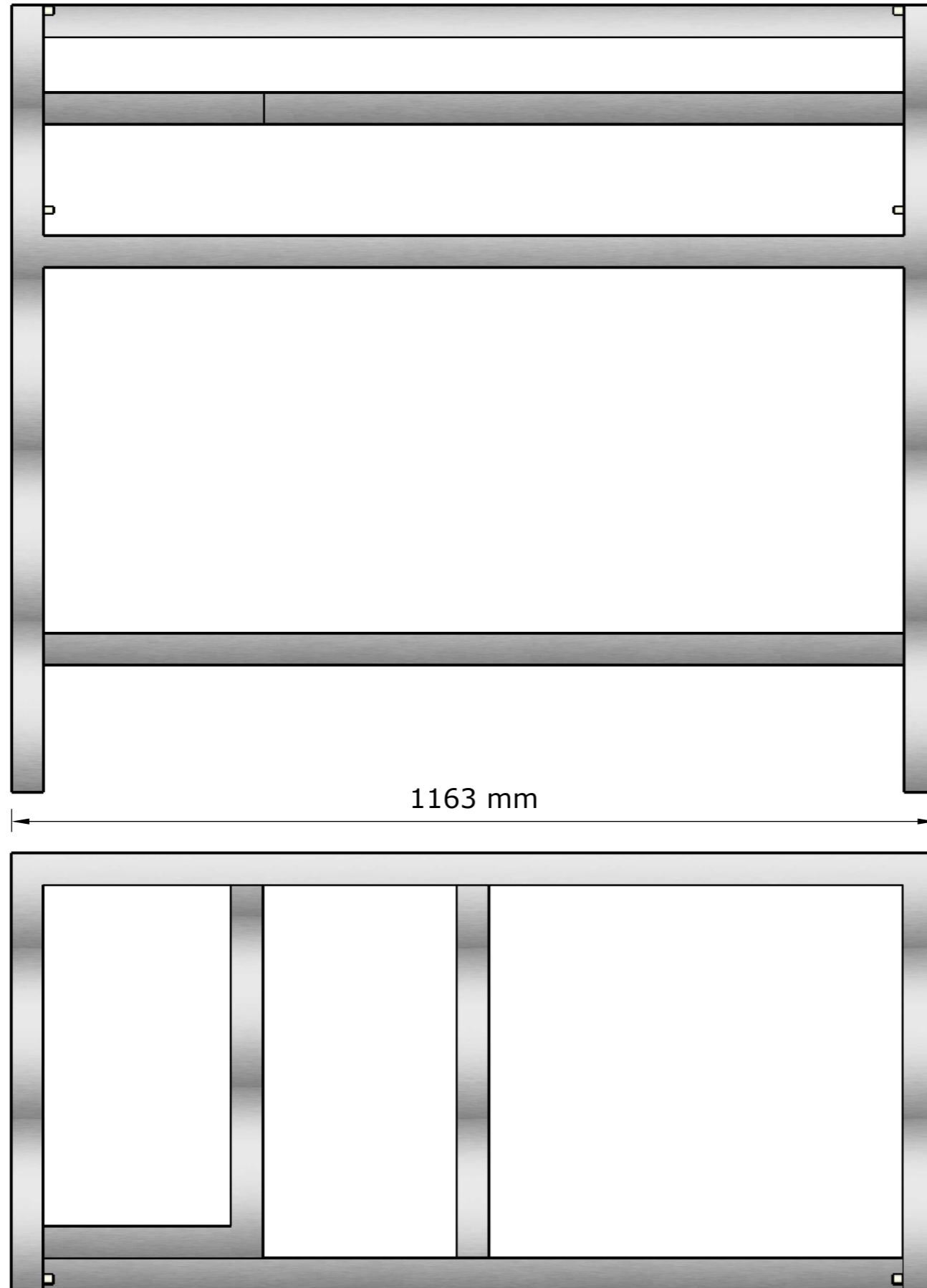

**All welds TIG or laser  
welded, nor filler wire,  
as-welded (not ground)**

# Combustion chamber construction

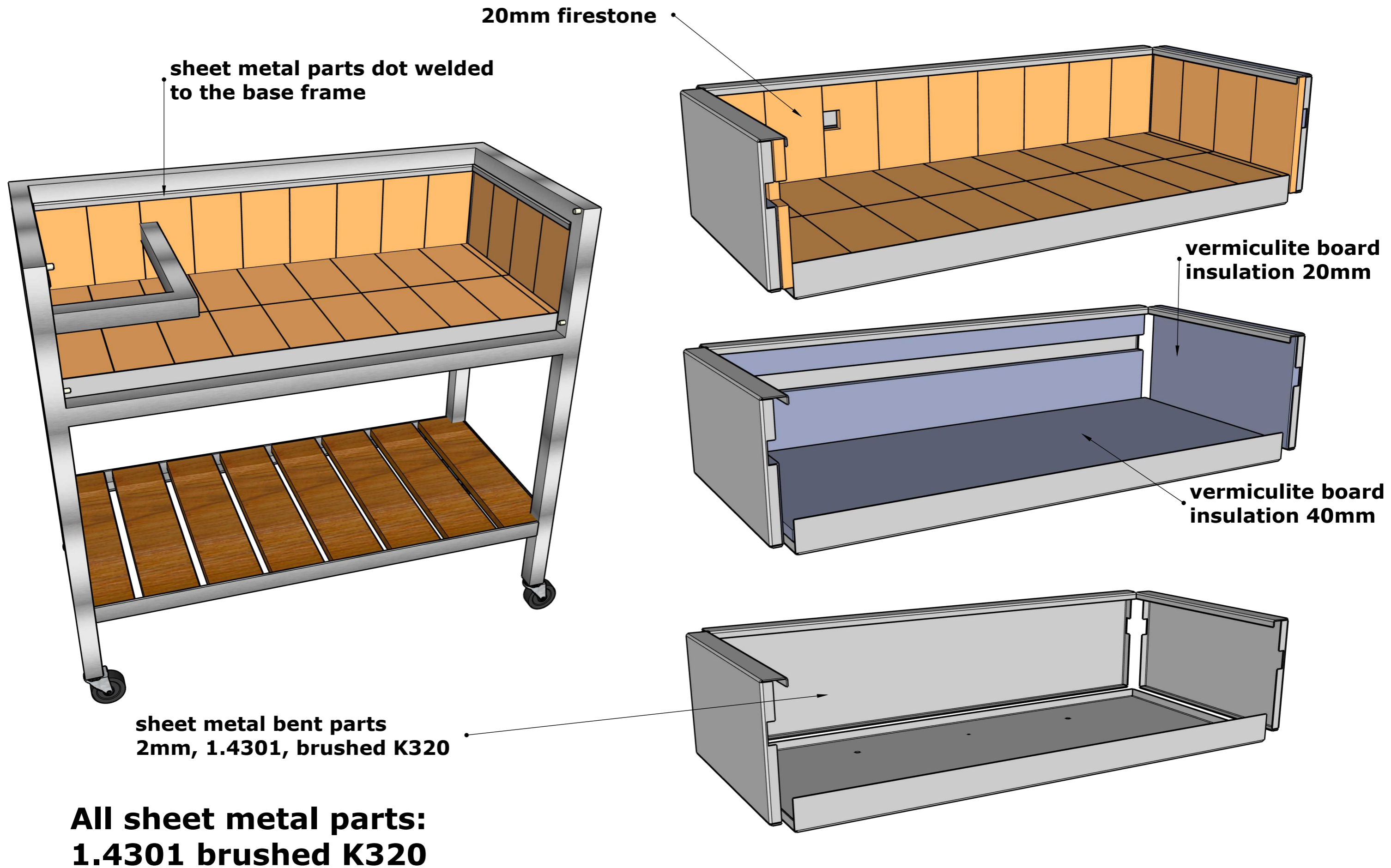

# Grill grate Lifting unit

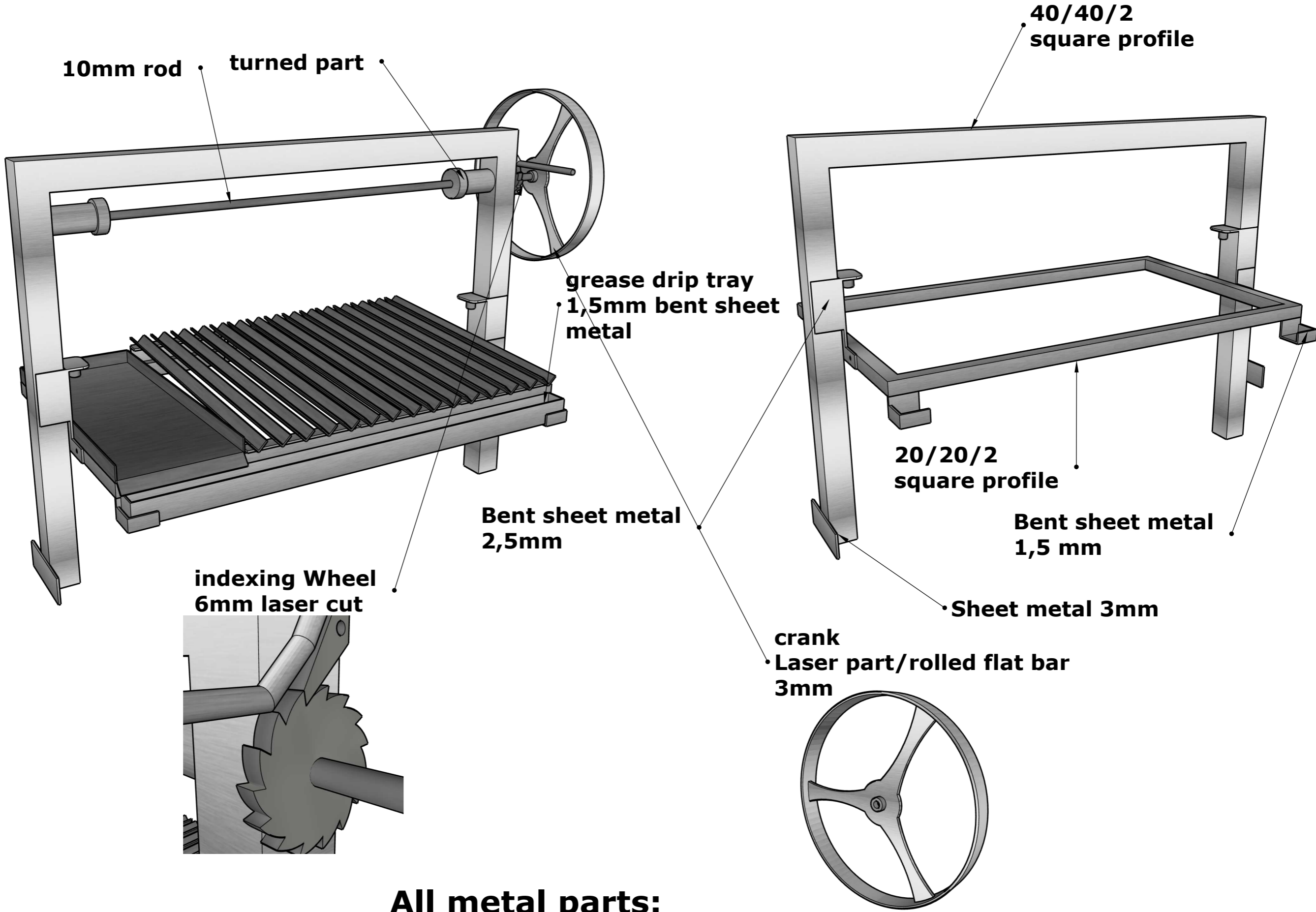

**All metal parts:  
1.4301 brushed K320**

# Grill grates

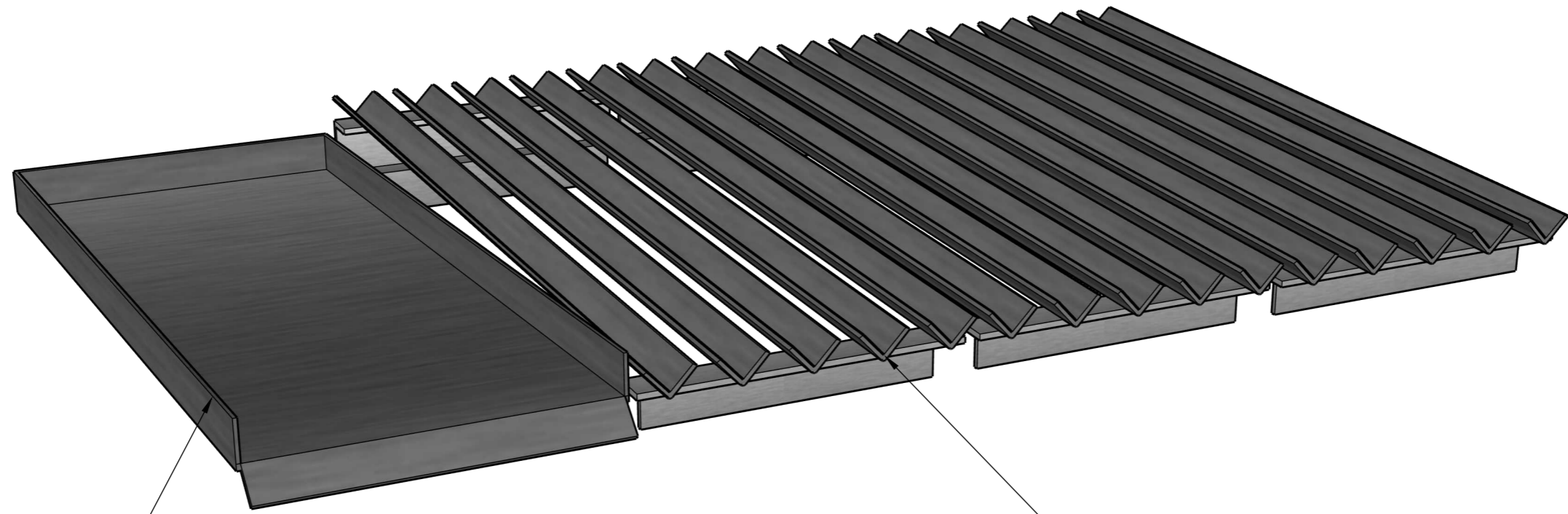

plancha  
4mm bent steel

grates  
1,5mm bent steel  
dot welded

**All sheet metal parts:  
1.4301 brushed K320**

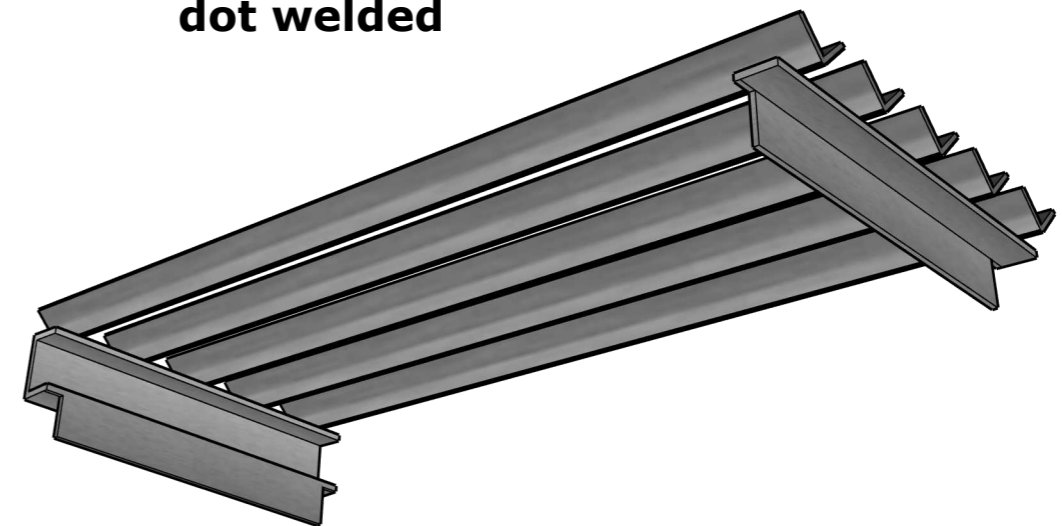

# Fire Basket/Wood shelf

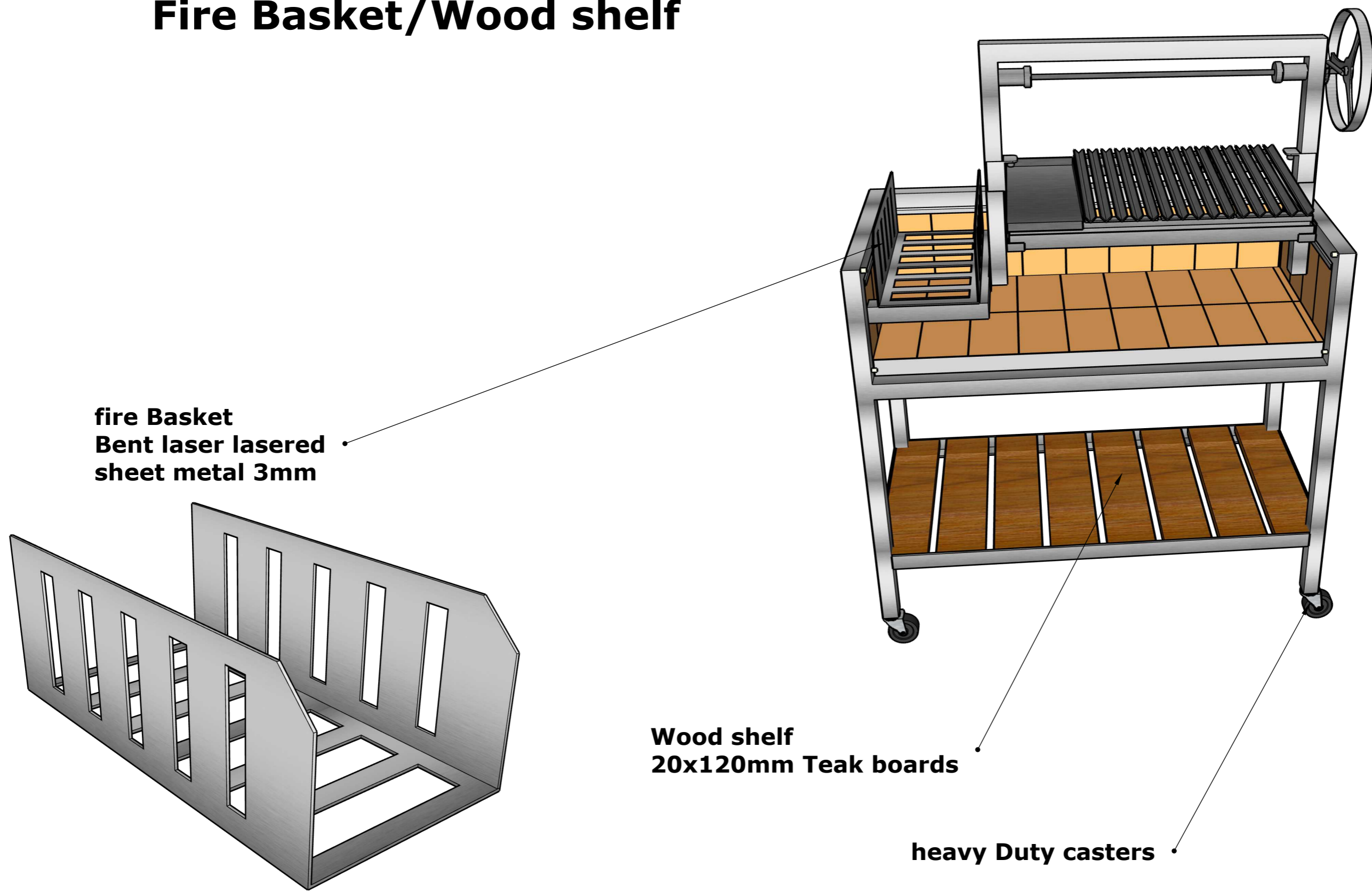

**fire Basket**  
**Bent laser lasered**  
**sheet metal 3mm**

**Wood shelf**  
**20x120mm Teak boards**

**heavy Duty casters**

# Flap/Handle



**Flap**  
• 1,5mm bent lasered sheet metal

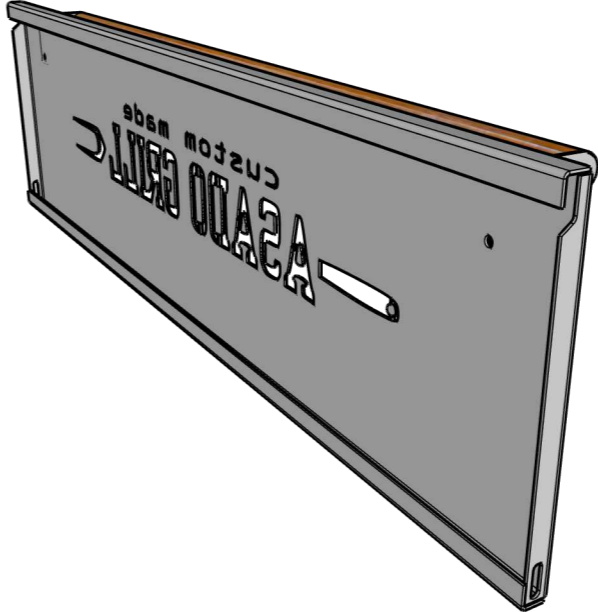

**Handle**  
30mm round Teak Wood bar

**All metal parts:**  
**1.4301 brushed K320**